

Sales guide



Index

3	The future of business printing
4	The evolution of office equipment
5	Why choose Epson inkjet?
6	The three pillars of great printing
7	A new standard through innovation
8	The ideal office solution
9	Features and benefits
11	Great performance, right up to the finish
12	Market-leading ink system
13	Options for your business
14	Enhanced graphical user interface
16	New optional solutions
18	Solutions that add value, streamline processes and improve workflow
20	Specifications
22	Dimensions and space requirements



The future of business printing

Epson inkjet printers use Heat-Free printing technology, which uses no heat in the ink ejection process. This delivers numerous advantages, including time and energy savings¹ – those all-important efficiencies every business thrives on.



Laser printer

From old, heat-based copiers to new Heat-Free Epson inkjets

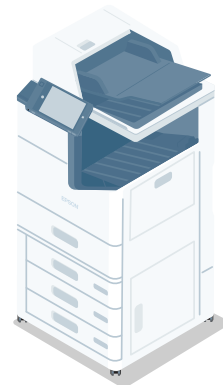

Inkjet printer



The evolution of office equipment

In the office equipment market, there's been an evolution in where customers are looking for value. From the earliest days of standalone copiers, the market now demands connected solutions that deliver real sustainability.

Stage 5

Hardware important – energy efficient, supporting companies achieve sustainable goals

Sustainable Solutions

Stage 4

Process and Workflow Process
Product is secondary to service
No perceived hardware difference

Solution Sale

Stage 3

Application focus
Software bundle
Hardware drives sales

Application Sale

Stage 2

Move to multifunctional devices
Introduction of network generation
Declining hardware differential

Connected MFP

Stage 1

Focus on specification
Clear hardware differences
Value was functionality

Standalone Copier



Why choose Epson inkjet?



PRECISIONCORE
HEAT•FREE



Save time with ready-to-go printing

No heat means no warm-up time when the printer is switched on or woken from sleep. It starts printing immediately.



Save energy with the lowest power consumption in their class¹

Thanks to Heat-Free printing technology, which uses less power because it does not use heat to warm up.



Fewer replacement parts

Laser printers have drums, transfer belt and fuses that require periodic replacement. Inkjet printers feature none of these parts, avoiding the need for their replacement.



Less intervention

The Heat-Free structure of Epson inkjet printers means that there are fewer parts that can fail, which means less maintenance intervention.

Heat-Free process comparison graphics

Laser printing process

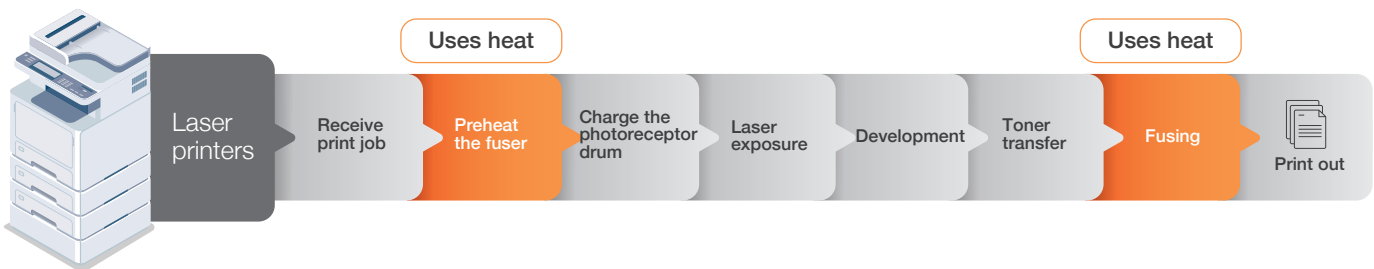

Inkjet printing process

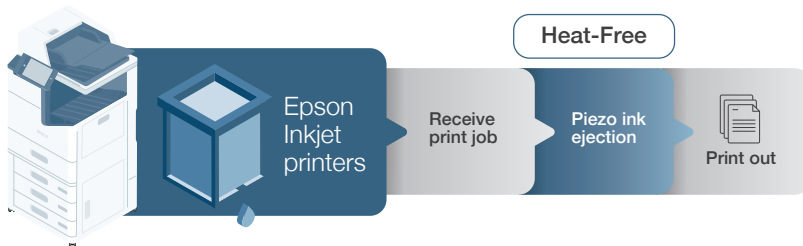

The three pillars of great printing

The WorkForce Enterprise AM-C series delivers up-to-the-minute printing capabilities for the modern office. With an innovative compact design, modular configuration and low energy consumption¹ – along with a host of technical innovations – it delivers on all three of Epson’s core pillars of printing.



Efficiency

Epson Heat-Free printing technology is incorporated in to the WorkForce Enterprise AM-C series, offering numerous benefits in terms of energy consumption¹, performance, and operating costs. Fewer consumables and reduced maintenance requirements also mean your customers save on resources.*



Reliability

Along with fewer consumables and less maintenance, printers in the series also deliver less downtime and intervention, as well as more user-friendly operation.



Productivity

With print speeds of 40, 50, 55 and 60 pages per minute covering all of your customers’ document needs, Heat-Free printing technology means efficient printing especially sleep mode.

*This explanation is only applicable for MicroPiezo fundamental advantage in principle. Product performance may vary.



A new standard through innovation

The WorkForce Enterprise AM-C series printers don't just match the performance of other printers in their class. Thanks to a range of technical innovations, they set a new standard for your customers.

The actual reach of the end user may vary and depends on the documents or graphics printed by the user. Other factors that affect range are the print interval, the number of pages per print job, and the print environment in general.

Outstanding security

The WorkForce Enterprise AM-C series printers offer updates and enhancements to make printing more secure than ever before. That includes:



Data protection

HDD encryption, HDD safe data erasure, Trusted Platform Module (TPM) and password encryption.



Device protection

Firmware signature verification, secure boot and new malware runtime intrusion detection.



Access control

User authentication, function restrictions and audit logs.



Document protection

Authentication printing, authentication scanning and job logging.



Communication protection

IPsec, SNMPv3 and new TLS1.3.



For additional physical security, you can add optional cassette locks to protect the paper cassettes when your printers are used in public spaces.

The ideal office solution



New paper path

The WorkForce Enterprise AM-C series printers feature a 'C-pass' path, requiring access on one side only. That means a simpler, shorter paper path, and easier jam removal and finisher connectivity.

Comfortable in every environment

Featuring compact, light and human-friendly design, with an agent built into the hardware to prevent yellowing, the clear, soft lines of the WorkForce Enterprise AM-C series printers sit comfortably in every working environment.



Compact design

By raising the transport belt vertically to move the ink system and minimising space around the paper cassette, the WorkForce Enterprise AM-C series printers are more compact than their previous models.

- Ink system
- Paper transport mechanism printhead



Features and benefits

Maintenance box

The WorkForce Enterprise AM-C A3 series printers have a moisturising liquid tank, to prevent the printhead from drying. This means significantly less maintenance ink is used, resulting in savings compared to the current WorkForce Enterprise models.

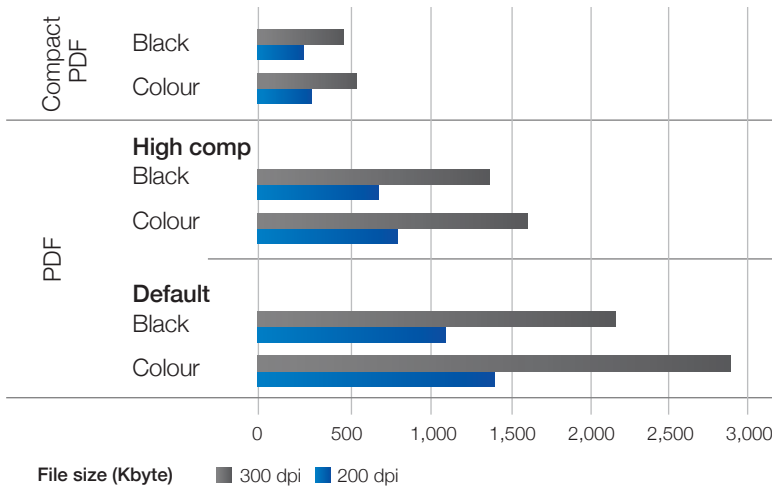

More compact PDFs

The WorkForce Enterprise AM-C series printers include high-compression PDF capability. This means they can create PDF files that are up to 83% smaller than the default PDF setting, improving transmission speed and HHD memory use*.

* Based on internal Epson testing

Superior image quality

Beautiful high-resolution output results in outstanding print quality, with no loss of speed or performance. With Epson's edge smoothing technology, text which is laid over imagery maintains a high image quality.

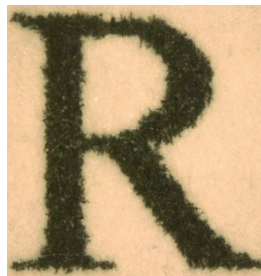

ON



OFF

Skip blank pages

Thanks to the new blank page skip scanning function, blank sheets of paper are recognised and are removed. This can support smaller file sizes.

Scan

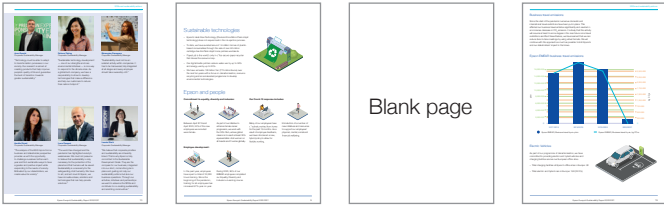

Result

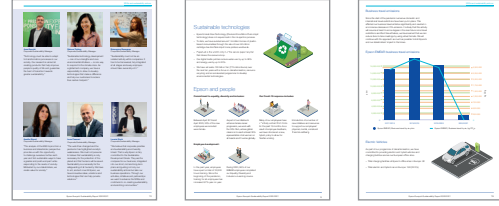

View savings with the fleet optimisation tool

You can help your customers manage their printers and view the savings they're making with our new fleet optimisation tool. Using the online dashboard, you can ensure they have the right printers, in the right places, across their business, and give them a free report that estimates energy and time savings, as well as productivity gains.



Great performance, right up to the finish

With the AM-C A3 range the quality extends way beyond the hardware. These printers offer versatile finishing capabilities once the job is complete.

A quiet, heat-free staple or booklet finishing unit delivers corner stapling for up to 50 sheets, and can output either 3,000 sheets (when booklet finisher installed) or 4,000 sheets (staple). Supporting offset stacking, the booklet finisher can also produce up to 20 saddle-stitched sheets, and 3 half-fold or tri-fold sheets.

The inner finisher is capable of stacking, shifting, and stapling your documents in 3 different positions, and supports optional 2- or 4-hole punch.



Staple finisher/booklet finisher

3-position stapling

Corner stapling

Up to 50 sheets

Supports optional hole-punch unit

Output capacity

Staple finisher – 4,000 sheets

Booklet finisher – 3,000 sheets

Supports offset stacking

Additional functionality with booklet finisher

Saddle-stitch (up to 20 sheets)

Half-fold (up to 3 sheets)

Tri-/C-fold (up to 3 sheets)

Inner finisher

3-position stapling (up to 50 sheets)

Supports optional 2 or 4 hole-punch unit

500-sheet output capacity

Supports offset stacking

Market-leading ink system

The WorkForce Enterprise AM-C series printers feature a new hydraulic-head type ink system which is smaller, easier to service, and achieves faster cleaning cycles and initialisation than air pressurisation systems. The ink cartridge is also fully used before disposal and easier to recycle.

Ink-saving technology

The AM-C nozzle verification technology flushing system, helps reduce ink consumption by checking the usage history of each nozzle during printing. The printers determine the appropriate amount of ink to be fired at the periodical flushing.⁴

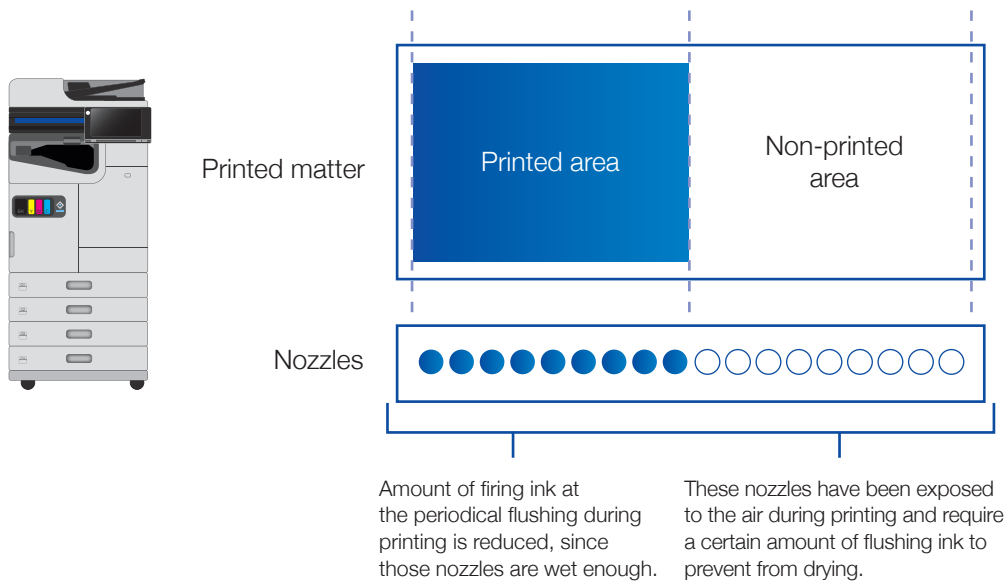

WorkForce Enterprise AM-C series

Hydraulic-head type ink supply system is used.

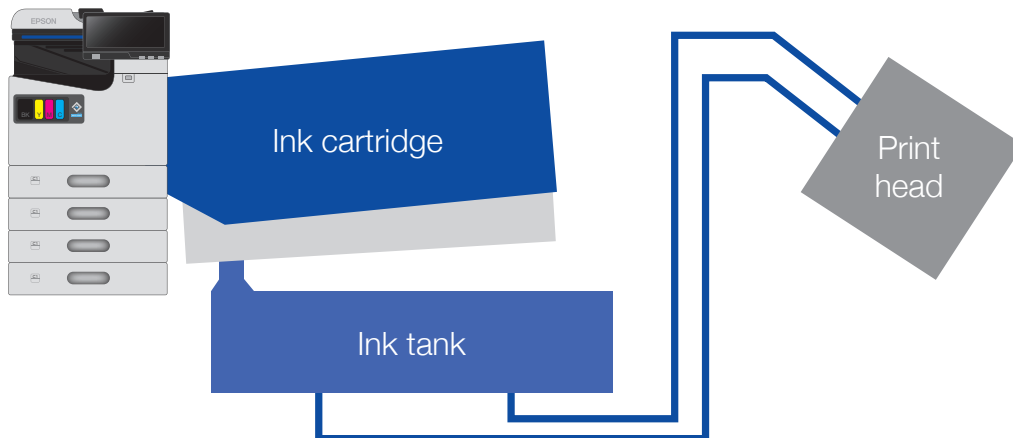

Hydraulic-head type ink supply system is used

Options for your business

You can configure the printers to match the precise needs of your business, with a range of optional functionality, including:



Wi-Fi dongle

Wi-Fi 5 Standard – 802.11ac, 2.4/5GHz.



EpsonNet Ethernet ports

One Ethernet port is available by default, with up to two available.⁴



Expansion board P1

Offering an additional CPU, needed for the embedded OCR.



HDD P1

One HDD is available by default, with a second⁴ available for enhanced data-loss protection.



Authentication table

The card reader can be inserted into the panel below the user interface so that 3rd party card readers can be added.⁴ Alternatively you can add a device table.



Super G3/G3 fax board

Allowing up to three fax lines to be installed on the AM-C4000/5000/6000 and one on the AM-C400/550.



Inner fax tray

Capacity of up to 100 sheets.⁴



Cassette lock

Protect paper cassettes when your printers are used in public spaces.

Enhanced graphical user interface

A new user interface with a 10.1" touchscreen makes for easier use, providing more customisation, simpler operation and more efficient workflows.

Customisable icons

Including three preset sizes, your choice of arrangement and the ability to customise the background.

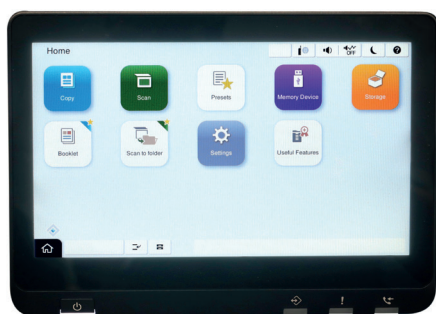

Small icons

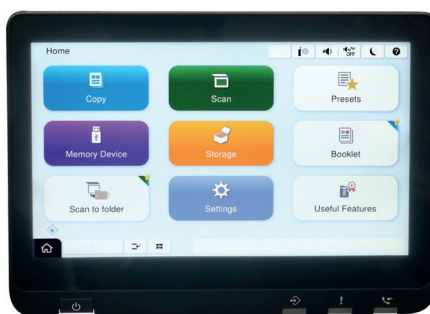

Large icons



Large and small icons

New user presets

Offering you one-touch operation, easy print or scan from the home screen and efficient copying and scanning workflows.



Change wallpaper

Via settings to easily add your own background.



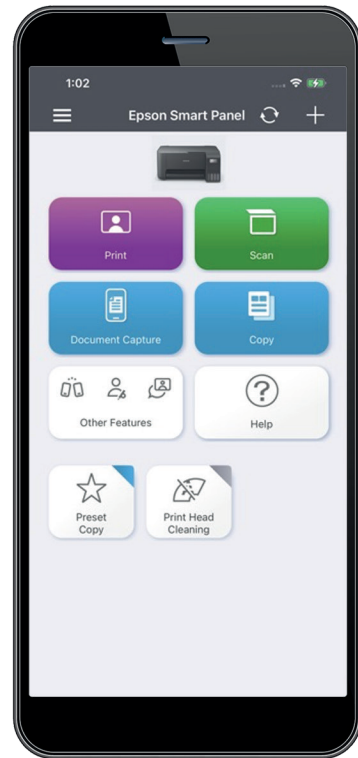

See all your options

The 'Useful Features' function means you can see new and optional functionality, along with brief descriptions of each.

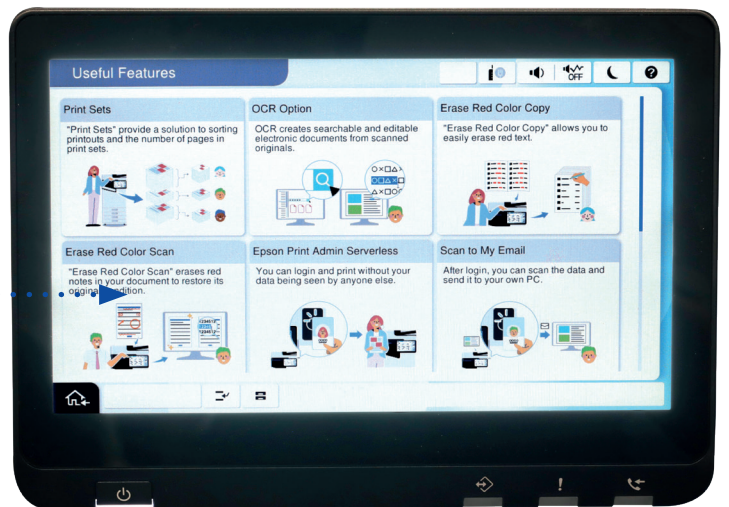
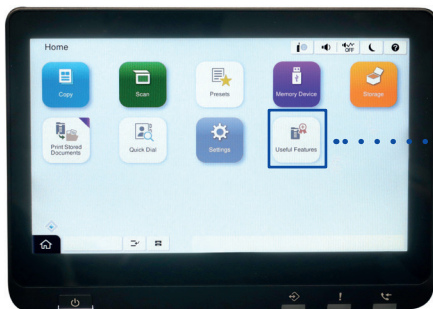

New optional solutions

More integrated capability

Your customers can choose to specify the WorkForce Enterprise AM-C series printers with a range of embedded solutions that add to their already powerful capabilities.

Embedded OCR

Thanks the option of an embedded OCR, customer can easily create searchable PDF files at the touch of a button without any software. The OCR can support 29 languages, offers fast processing and high recognition rates for exceptional accuracy.

IP-Fax

With the IP-Fax function, customers can send or receive documents directly from and to the printer via their chosen network.



Print sets

The 'print sets' function makes the sorting out printouts and page numbers within sets simple and straightforward.

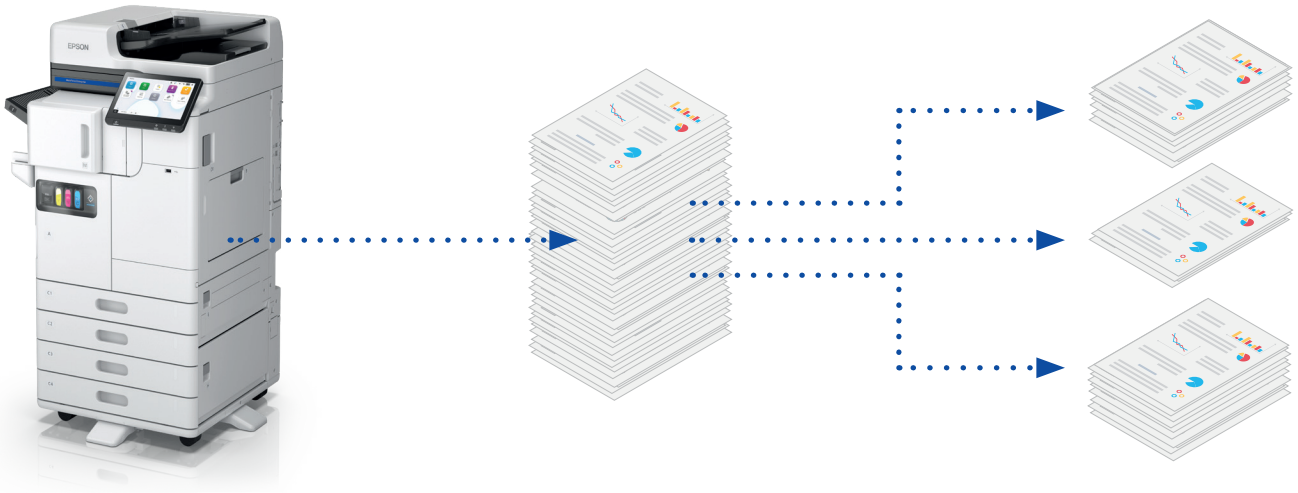

Erase red colour

To avoid printing any deletions or marked-up comments, 'Erase Red Colour Copy' automatically erases any red items in the document before printing.



Solutions that add value, streamline processes and increase workflow

Epson
Solutions Suite

Epson Solutions Suite

Epson business inkjets offer a full suite of advanced printing solutions designed to help businesses easily manage the installation, configuration and operation of their print environment.



With workflow and security, fleet management, remote services, and third-party integration, Epson Solutions Suite has you covered.

For more about Epson solutions please visit support.epson.net/stories/en

Fleet management



Epson Device Admin (EDA)

Allows users to control, analyse and manage their printer fleet centrally from one intuitive interface, designed to increase productivity, reduce costs and ensure maximum security.

Workflow and security



Epson Print Admin (EPA)

EPA is a server-based solution that creates a secure printing, scanning and copying environment through user-authentication with card readers, logins/passwords and PIN codes. It also offers additional features such as 'scan and send to me' (email and folder), employee-education notifications and enhanced administrative tools that provide welcome boosts to productivity, environmental goals and efficiency.

The Advanced Workflow functions enable administrators to easily create scan profiles with document capture, processing and delivery to predefined destinations, including cloud-storage services. Automated capture enables the creation of Searchable PDF, PDF/A in 29 languages, job separation with barcodes, folder and document naming with Zonal OCR, barcodes, skip blank pages, and much more.



Epson Print Admin Serverless (EPA Serverless)

Enables business customers to seamlessly integrate the WorkForce Enterprise series into their security and compliancy rules and regulations without the burden of maintaining a server system.



Document Capture Pro (DCP)

Document Capture Pro (DCP) enables individuals to scan, save and share information around the business easily. Advanced features for naming, separating and routing documents makes scanning easy – and logical. Save and send files in common formats and create simple job profiles for one-touch push scanning.

Scan to standard destinations such as email, folder and FTP or upload your scanned documents to popular cloud services such as OneDrive, OneNote, SharePoint Online, Google Drive and Dropbox.

Boost DCP with the Optional DCP Enhanced OCR to benefit from a high OCR recognition rate and convert paper documents into Searchable PDF, DOCX, XLSX and PPTX.



Document Capture Pro Server (DCPS)

For our supported devices, Document Capture Pro Server allows administrators to manage push scan functions without installing software on individual computers.

Mobile and Cloud printing/scanning



Mobile and Cloud printing

Epson's mobile and cloud printing services allow users to print and scan from their smartphone and tablet – in the office and on the go.



Epson iPrint Mobile App

Print to an Epson printer from practically anywhere, anytime, using your smartphone or tablet PC – Epson iPrint makes it really easy. Just download and install the free app and you're ready to print web pages, Microsoft Office documents, photos and PDFs, as well as scan and copy.



Epson Email Print

Print from any device such as phone, tablet or laptop, anywhere in the world, by simply sending an email across the internet to the printer.



Epson Scan to Cloud

Scan documents directly to email or cloud storage accounts (SharePoint Online, Teams, OneDrive for Business, Google Drive, Dropbox, Box and Evernote).



Epson Remote Print Driver

Advanced printing from anywhere using your computer.

Remote service and support



Epson Remote Services (ERS)

Reduce service costs using our cloud-based device monitoring and management system that delivers advanced remote diagnostics. Secure and easy to integrate, increase customer satisfaction by enabling faster response times, fewer on-site visits and higher first fix rates. Track and monitor device usage, and minimise printer downtime.



ERS Embedded Agent (ERS-Agent)

Benefit from the added value of ERS in combination with the embedded agent on the WorkForce Enterprise AM-C series for a seamless setup and use.

Third party integration



Epson Open Platform (EOP)

Users gain complete control of their printing operations via a web-based application that allows them to adapt their printer to meet specific and changing business requirements, as enterprise IT systems evolve. Third party ISV solutions are compatible with Epson Open Platform devices.

Please get in touch with your Epson local representative for a full list of third party solutions compatible with Epson devices.

Specifications

	AM-C4000	AM-C5000	AM-C6000	AM-C400	AM-C550
Functions	A3 multifunction up to 4-in-1 device			A4 multifunction up to 4-in-1 device	
First page out time (FPOT)* Mono / Colour	6 sec	5.1 sec	4.5 sec	4.9 sec	4.3 sec
Print speed (ISO)² Mono / Colour	40 ppm	50 ppm	60 ppm	40 ppm	55 ppm
Maximum print resolution	600 × 2,400 dpi				
PCL & PostScript compatible	Yes				
Print from USB	Yes (PDF / TIFF / JPEG)				
Scan speed (ISO)	60 ipm (simplex) 120 ipm (duplex)			50 (simplex) 100 ipm (duplex)	
Scan resolution (Optical / Interpolated)	600 × 1,200 dpi / 9,600 dpi			600 × 600 dpi / 9,600 dpi	
Scan Functions	Scan to Email, Scan to PC, Scan to Cloud Services (SharePoint Online, Teams, OneDrive, OneNote, Google Drive with Epson Document Capture Pro), Scan to FTP, Scan to Network folders, Scan to USB				
Copy speed (ISO)³ Mono / Colour	40 ipm	50 ipm	60 ipm	40 ipm	55 ipm
Zoom ratio	25 – 400%				
Copy resolution	Input 600x600dpi / Output 600x2,400dpi			Input 600x600dpi / Output 600x1,200dpi	
Fax transmission speed**	Up to 33.6 Kbps				
Fax memory	6 MB / 550 pages				
Mobile and Cloud printing /scanning	Epson Connect, Epson iPrint Mobile App, Epson Email Print, Epson Scan to Cloud and Epson Remote Print Driver				
Epson Solution compatibility	Epson Print Admin, Epson Print Admin Serverless, Epson Open Platform, Epson Remote Services, ERS Embedded Agent, Epson Device Admin, Document Capture Pro, Document Pro Server, Document Capture for Mac, Embedded OCR, IP-Fax, Print Sets, Erase Red Colour and Epson Smart Panel				
Interfaces	SuperSpeed USB, Internal USB 2.0 Type A for Card Reader, Wired Network (10BaseT / 100Base-TX / 1000-Base-T), Wireless LAN (IEEE 802.11a/b/g/k/n/ac/r/v, Wi-Fi 5, Wi-Fi Direct) using optional Wi-Fi dongle				
Plain paper size	A3, A4, A5, B6, B5, B4, Letter, Executive, C5 (Envelope), User defined			A4, A5, A6, B6, C4 (Envelope), C5 (Envelope), C6 (Envelope), DL (Envelope), No.10 (Envelope), Letter, Half Letter, Executive, Oficio, Folio, Legal, User defined	
Paper capacity	Standard: 1,150 sheets (500 sheets per tray + 150 MP Tray) Max: 5,150 sheets			Standard: 600 sheets (500 sheets tray + 100 sheets MP Tray), Max: 2,100 sheets	
LCD display	25.7 cm colour touch-screen				
Power consumption Operating / Ready / Sleep / Power Off	110 Watt (standalone copying, ISO/IEC 24712 pattern), 1 Watt (sleep mode), 46 Watt (Ready), 0.1 Watt (Power off), TEC 0.22 kWh/week	115 Watt (standalone copying, ISO/IEC 24712 pattern), 1 Watt (sleep mode), 46 Watt (Ready), 0.1 Watt (Power off), TEC 0.23 kWh/week	115 Watt (standalone copying, ISO/IEC 24712 pattern), 1 Watt (sleep mode), 46 Watt (Ready), 0.1 Watt (Power off), TEC 0.25 kWh/week	0.9 Watt (Sleep mode), 84 Watt (Copying), 36 Watt (Ready), 0.1 Watt (Power off), TEC 0.19 kWh/week	0.9 Watt (Sleep mode), 86 Watt (Copying), 36 Watt (Ready), 0.1 Watt (Power off), TEC 0.21 kWh/week
Dimensions (W × D × H)***	555 × 593 × 963 mm			465 × 490 × 570mm	
Weight***	118 kg			56.3 kg	



Options for A3 AM-C range

	Inner finisher	Staple finisher	Booklet finisher	Remarks	
Stackable number	Upper	–	200 sheets	–	80 gsm Exclusively for FAX
	Main	500 sheets	Max 4,000 sheets (A4, 1 sided/2 sided)	Max 3,000 sheets (A4, 1 sided/2 sided)	80 gsm Length: Up to A4 SEF
			Max 1,500 sheets (A4, 1 sided/2 sided)	Max 1,500 sheets (A4, 1 sided/2 sided)	80 gsm Longer than A4 SEF
Lower	–	–	Saddle stitching: 20 sheets (60-90 gsm) / 10 sheets (91-105 gsm)	–	
Staple number	50 sheets	Max 50 sheets	–	–	60 – 90 gsm Length : Up to A4 SEF
Staple position	3	3	–	–	Right & Left corner, 2 points
Folding					Center folding: 3 sheets (60 – 90 gsm) / 1 sheet (91 – 105 gsm) Tri-folding: 3 sheets (60 – 90 gsm) / 1 sheet (91 – 105 gsm)

Staple finisher /Booklet finisher

3-position stapling

Corner stapling
Up to 50 sheets

Supports optional hole-punch unit

Output capacity
Staple finisher – 4,000 sheets
Booklet finisher – 3,000 sheets

Support offset stacking

Additional functionality with booklet finisher
Saddle-stitch (up to 20 sheets)
Half-fold (up to 3 sheets)
Tri-/C-fold (up to 3 sheets)

Inner finisher

Stacking, Shifting, Stapling
3 position (Right / Left corner / 2 point)

500 sheets – 80 gsm A4 LEF
300 sheets – 80 gsm longer than A4 LEF

Stapling
Max 50 sheets 60 – 90 gsm (Up to A4 SEF)

Supports optional
2 – 4 Hole punch



Staple finisher



Inner finisher

* Time between the receiving print data, to the complete exit of the first page. For detailed information on printing speeds please visit epson.eu/workforce-enterprise

** Fax optional at an additional cost

*** Main unit with dual cassette. Size is the printer footprint, not including the display panel.

Product variations key: N – Network Connectivity W – Wireless Connectivity F – Fax D – Duplex T – Includes optional paper tray

Product information is subject to change without prior notice. For up-to-date specifications please visit epson.eu/workforce-enterprise

Dimensions - Main unit

AM-C4000, 5000 and 6000



Main unit + caster table



Main unit + cabinet



Main unit + dual cassette



Main unit + caster table + staple finisher + saddle unit + high capacity tray (HCT) + dual cassette



Main unit + staple finisher + puncher + dual cassette

* 593 mm is the size of the printer footprint, not including the display panel. Measurement is 620 mm including display panel.

Dimensions - Inner Finisher Configuration

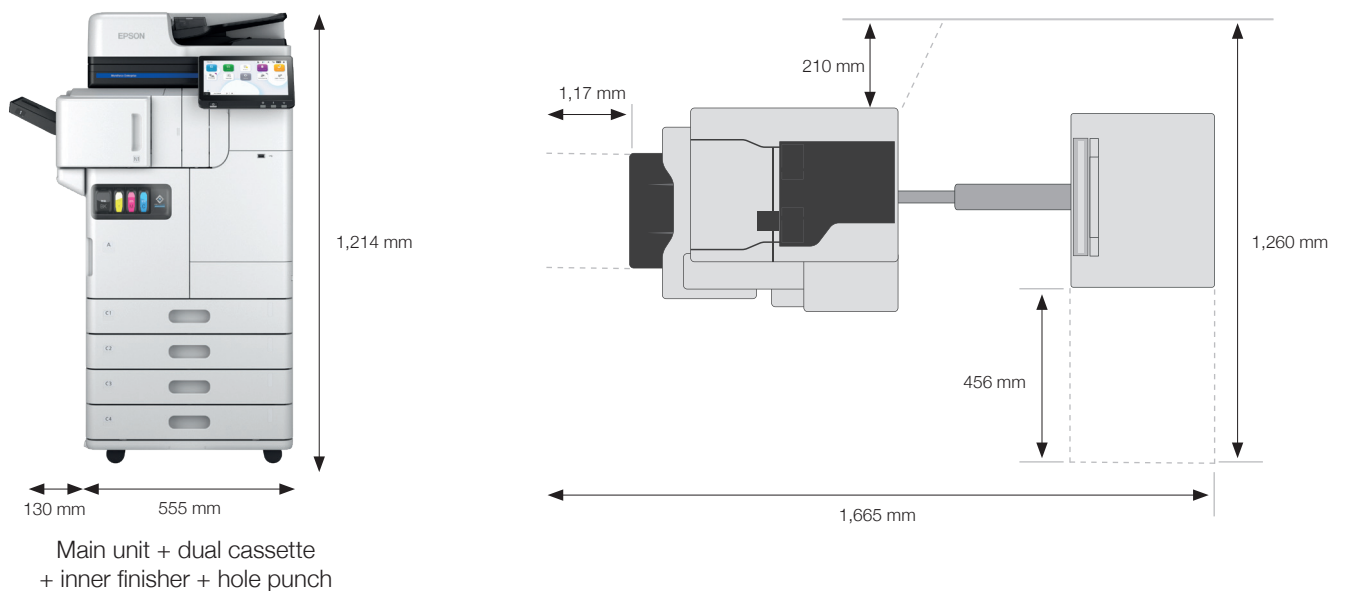
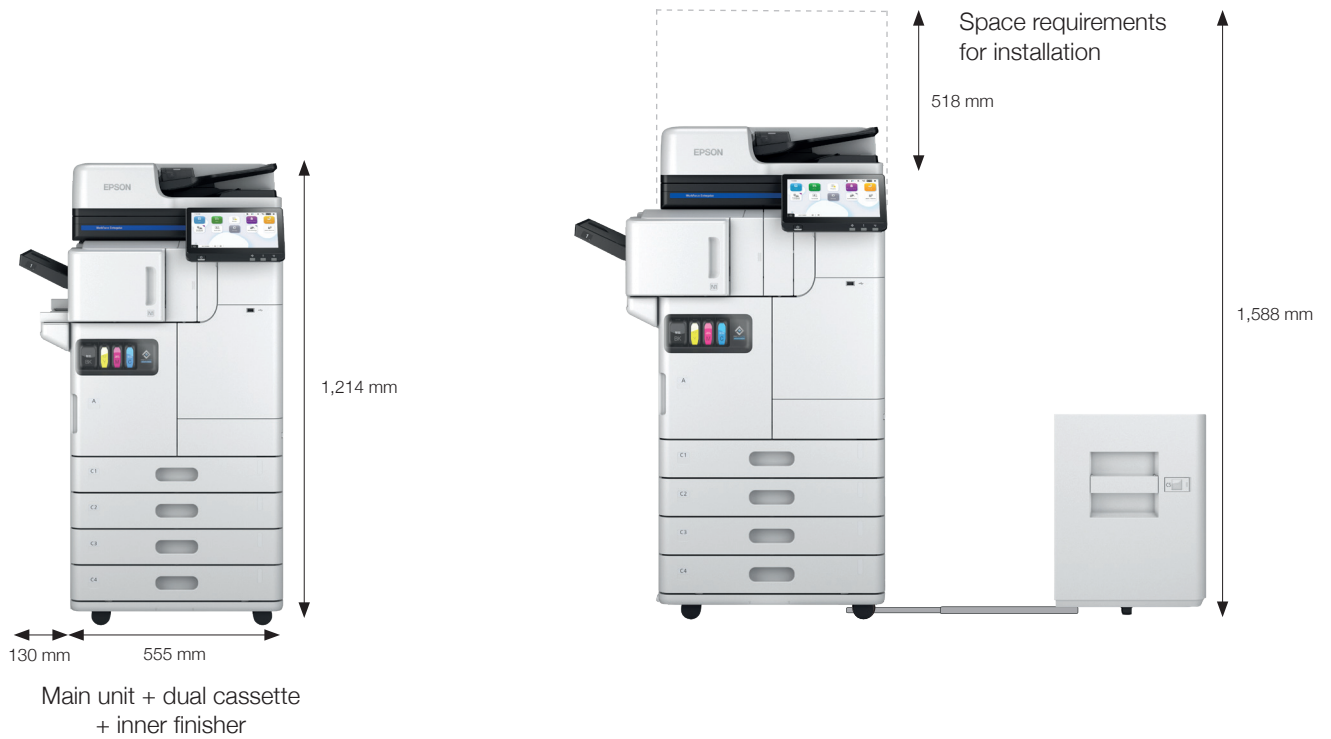

Dimensions - Main unit

AM-C400 and 550



Main unit



Main unit + single cassette



Main unit + single + dual cassette



Main unit + tall cabinet



Main unit + single cassette + tall cabinet

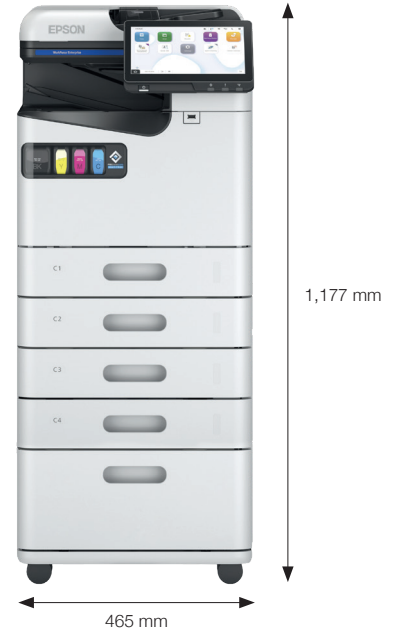

Main unit + single cassette + dual cassette + short cabinet

*490 mm is the size of the printer footprint, not including the display panel. Measurement is 517 mm including display panel.

¹ Compared to best-selling similarly-featured colour laser printers in Europe (IDC, Quarterly Hardcopy Peripherals Tracker, Q1 2023 to Q4 2023 shipments, published Q1 2024). Comparison based on the Typical Energy Consumption (TEC) as published by ENERGY STAR or the manufacturers' official specifications. Where only TEC 2.0 data is available an equivalent TEC 3.0 value has been calculated. If no data is available the products have been removed from the comparison. Epson models included: WF-C20750, AM-C6000, AM-C5000, AM-C4000, AM-C400, AM-C550, WF-C879R, WF-C878R, WF-C579R, WF-C529R, WF-C5890, WF-C5390.

² The productivity has been determined in accordance with ISO 24734, using default settings. The average of ESAT from the office category test. The full detailed report can be obtained from your local Epson sales office.

³ The productivity has been determined in accordance with IEEE/ISO 24735 (ESAT) and IEEE/ISO 29183 (sESAT), using default settings. The average from the office category test. The full detailed report can be obtained from your local Epson sales office.

⁴ Applies to AM-C4000/5000/6000 only.

For latest version of all specs, please check www.epson.eu/workforce-enterprise

For further information please contact your local Epson office or visit www.epson.eu/contact-us

Algeria +213 770 938 617 Austria 01 253 49 78 333 Belgium +32 (0)2 792 04 47 Czech +420 246 037 281 Denmark 44 50 85 85 Ethiopia +254700760366
 Finland 0201 552 091 France 09 74 75 04 04 (Cost of local call, operator charges may apply) Germany +49 (0) 2159/92 79 500 Greece (0030) 211 198 62 12
 Hungary 06800 147 83 Ireland 01 436 7742 Israel (+972)-3-5751833 Italy 02-660321 10 (0,12 €/min) Kenya +254 207 904 566 Luxembourg +352 27860692
 Middle East +9714 2677638 Morocco +212 520 134 040 Netherlands +31 (0)20 708 5099 Norway +47 67 11 37 00 Poland +48 22 295 37 25 (0,16 zł/min)
 Portugal 707 222 111 Romania 0040 214025024 Slovakia +421 232 786 682 Southern Africa +27 (0) 10 109 5320 Spain 93 582 15 00
 Sweden +46 8 5051 3701 (Mobilsamtal – 0,99 kr/min, Lokala samtal – 0,30 kr/min, Utlandssamtal – 0,89 kr/min) Switzerland 022 592 7923
 Tanzania +255 080 011 1014 Tunisia +216 9811 5564 Turkey (0212) 3360303 Uganda +256 205 491 148
 United Kingdom 0871 42 37766 (+10p per minute plus network extras) West Africa +2349046648285



Please recycle responsibly

EPSON®

Trademarks and registered trademarks are the property of Seiko Epson Corporation or their respective owners. Product information is subject to change without prior notice.