

# Expanded colour gamut with high print speeds



life



mom



Warden & White  
ENGLAND



Geranium, Orange & Cardamom  
cleansing hand wash  
savon liquide pour les mains

#### Lather and rinse

**Warning:** Avoid contact with eyes.  
If product gets in eyes rinse immediately  
with clean warm water. If skin irritation  
occurs discontinue use. If irritation  
persists consult your doctor.

**Ingredients:** Aqual/Water, Sodium  
Laureth Sulfate, Glycerin, Cocamidopropyl  
Betaine, Glyceryl-2-Cocostate, PEG-4  
Rapeseedamide, Octadecyl  
Di-1-Butyl-4-Hydroxyhydroxymethyl  
Sodium Chloride, C12-13 Alkyl Lactate,  
C12-13 Alcohol, PEG-6-Capryl/Capric  
Glycolides, Parfum/Fragrance, Citronellol,  
Hexyl Cinnamal, Linalool, Alpha-Isomethyl  
Ionone, Sodium Benzoate, Potassium  
Sorbate, Citric Acid, Lactic Acid.



EPSON®

# Outstanding colour at high productivity

The SurePress L-6534VW with orange ink is a premium quality UV inkjet digital label press designed for high productivity and versatility. Producing vibrant colours at print speeds up to 50 meters per minute.

Designed by Epson, the L-6534VW ensures the high print quality you demand is delivered at the speed you need, producing richer colour reproductions to meet diverse customer requirements.

With built-in reliability and automated processes, the press ensures consistent results, time-after-time. By adding orange ink to the print process, we've expanded the L-6534VW's colour gamut, enabling effortless reproduction of special colours to take brand colour accuracy and consistency to new levels.



Liquors



Industrial Products



Pharmaceutical



Household Products



Novelty



Food and Beverages



Cosmetics



Window Graphics/POP

Extended colour gamut up to 92% Pantone® coverage\*

UV LED pinning between colours ensures sharper text and line work

A  
AURA  
Hair Toners

Accurate and consistent colour-to-colour print registration

\* The Epson SurePress L-6534VW (CMYKOr) printer has been evaluated and approved by Pantone as being capable of achieving 92% of the PANTONE® Solid Coated Colors when used in conjunction with the FassonAB074 PP Top White substrate system and Epson ink. 92% calculated using CIEDE2000 $\leq$ 1.5 tolerance.

# The power of colour

## Epson UV inks

Epson manufactures its own inks and can control every aspect of the production.

With significant investment in systems and hygienic control processes, Epson also applies Good Manufacturing Practices.

The SurePress UV inks comply with European Food Contact material regulations for food packaging.

This makes them suitable for a wide range of labelling applications including food, beverage, industrial, cosmetic, toiletries and pharmaceuticals.



## High opacity white ink

The single pass, high opacity white ink delivers a bright white to create optimum visual impact, and is an ideal base layer for printing vivid colours on clear or metallised films at speed. It has the flexibility to reproduce fine lines and text where needed.



### Extended colour gamut

Epson's highly pigmented UV inks are designed to deliver the widest colour gamut with five colours plus white ink. The L-6534VW gives brand owners and designers the scope to create with powerful, vibrant lifelike colours. The digital label press achieves impactful and rich colour reproductions with minimum ink usage.

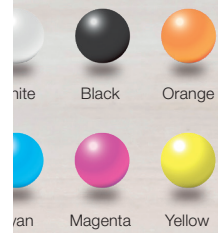

# Designed for precision and adaptability

All print heads and ink in the SurePress L-6534VW with orange ink are developed by Epson. By focusing on precision, consistency, and reliability of the press – Epson ensures your print runs are efficient and productive, while maintaining the highest print quality time after time.

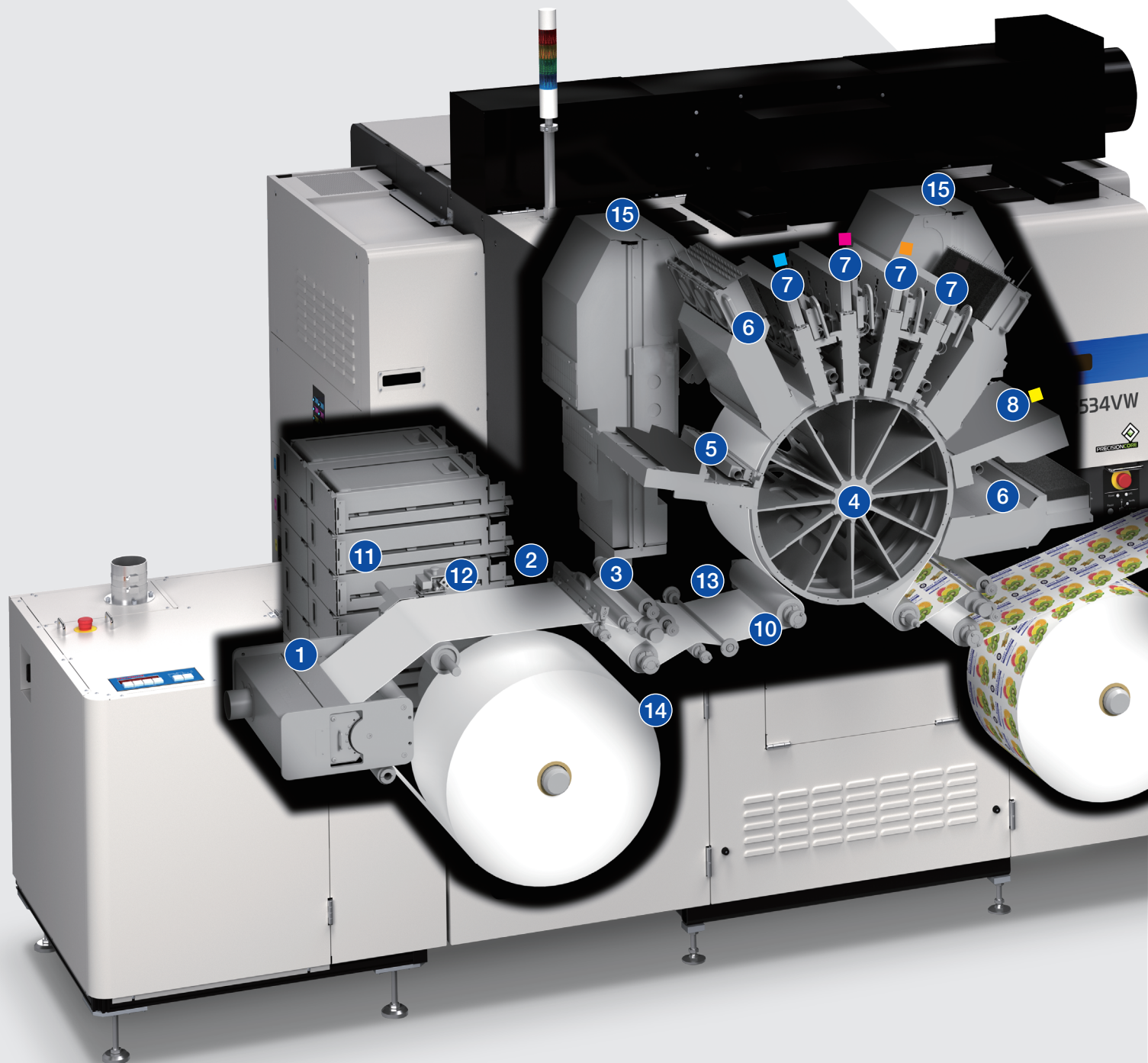

The L-6534VW with UV LED pinning lamps and central drum system, is a space-saving compact design, which integrates all of the functions required for label production.

This includes a corona treater, web cleaner, ioniser, an additional UV curing unit, plus white ink - all fitted as standard.

The high-resolution print heads print up to 600 x 1200 dpi. This versatile press configuration delivers a stable and flexible print process, giving you everything you need for repeatable prime label production, 24/7.

For further piece of mind, the Automatic reverse feed function ensures that substrate waste is minimised.

1. Corona treater
2. Ioniser
3. Web cleaner
4. Central drum platen
5. White ink linehead / mist vacuum
6. LED UV curing lamps
7. C M Or K lineheads / LED UV pinning lamps / mist vacuum
8. Yellow linehead / mist vacuum
9. Additional UV lamp
10. Substrate width sensor
11. Substrate edge sensor
12. Splice detection sensor
13. Re-registration eye-mark sensor
14. Roll diameter sensor
15. Ink circulation systems



PRECISIONCORE

# High-precision jetting and dot control

Enjoy registration accuracy with the Epson Drum Platen, print vivid colours using a wide gamut ink set. Minimise waste with electronic web registration for faster make ready.

## Drum Platen web feeding

The substrate is held under tension around the drum as it passes all the printhead colours providing accurate and consistent colour-to-colour registration.

The Drum Platen is a highly accurate web feeding technology which prevents meandering and skewing of the substrate.

The very small (0.7mm) gap between the Printhead and substrate is kept to a minimum producing crisp text and fine lines.

The electronic web registration on the L-6534VW reduces waste and saves time during job changeovers.

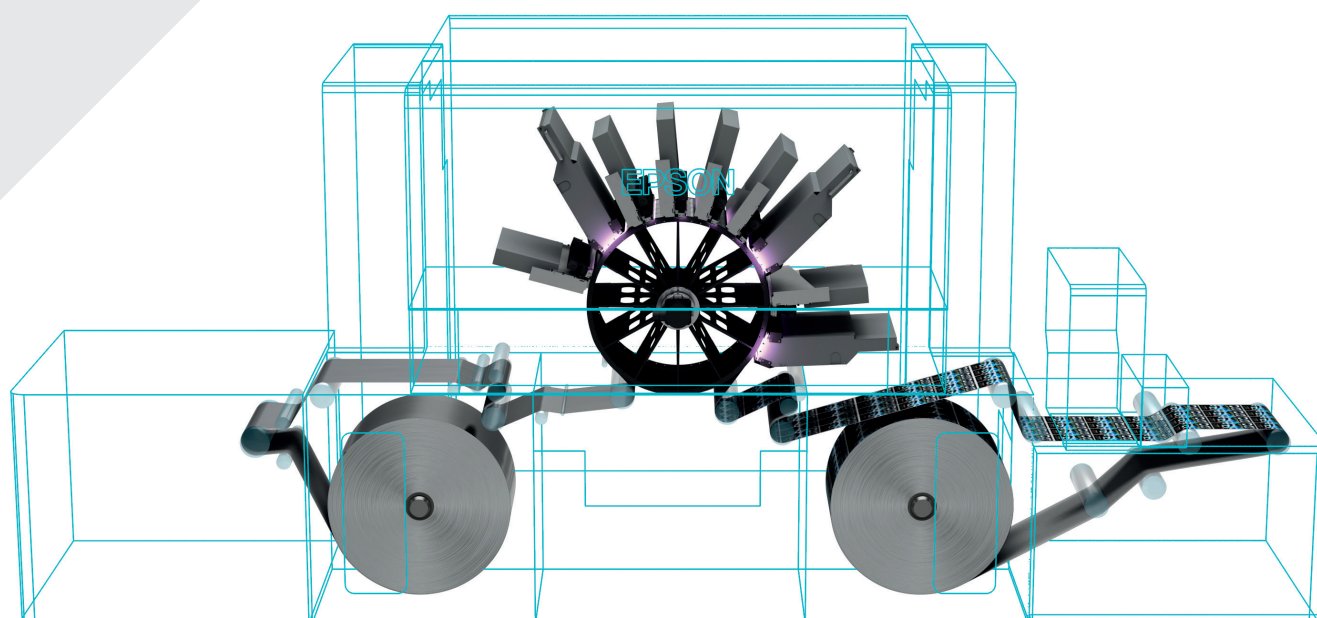
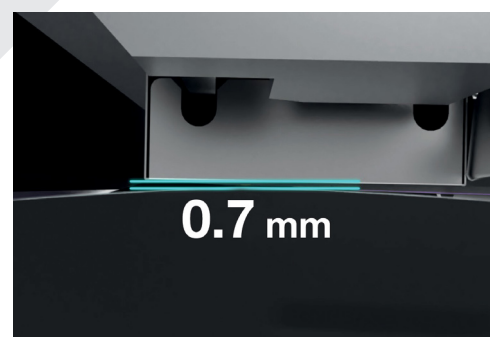

# Sharper, more vivid images with LED UV Colour Pinning Control

Epson's LED UV colour pinning system partially cures and controls ink spread for finer tonal gradation, sharper images and vivid colours.

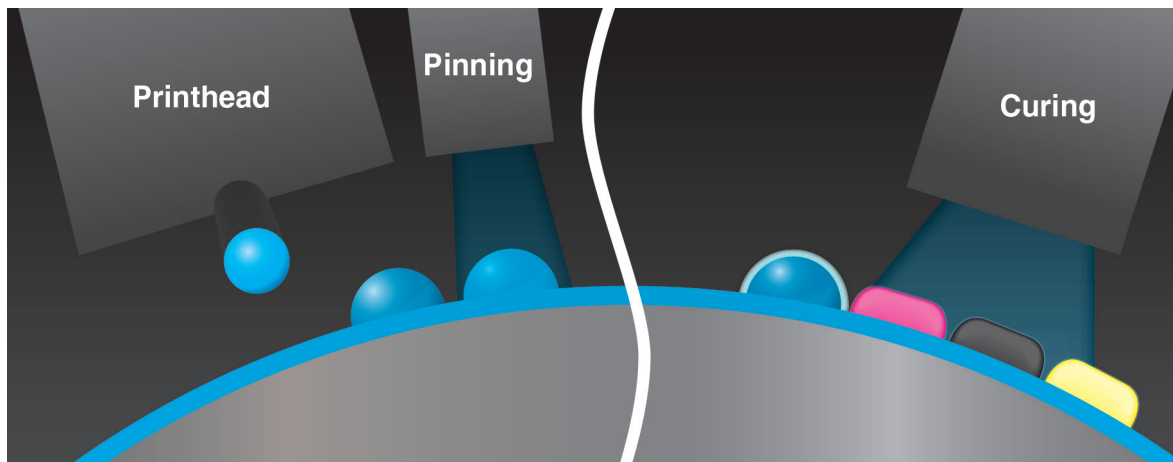

## Perfect finish

Applying UV light immediately after each colour is printed creates perfectly round drops in their correct positions.

Halftone images and detailed text are effortlessly reproduced by preventing ink drops from spreading or deforming.

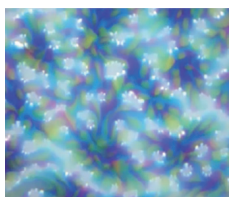

Without pinning

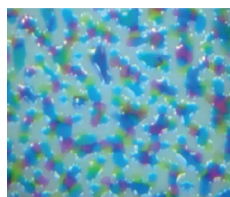

With pinning

# Increase flexibility with variable data printing

With the increase in demand for product personalisation, full colour variable data printing (VDP) option enables variable text, barcodes and images to be printed.

The Epson Workflow offers support through the Esko Dynamic VDP plugin in, Illustrator and DFE Server.

## Black and colour VDP workflows

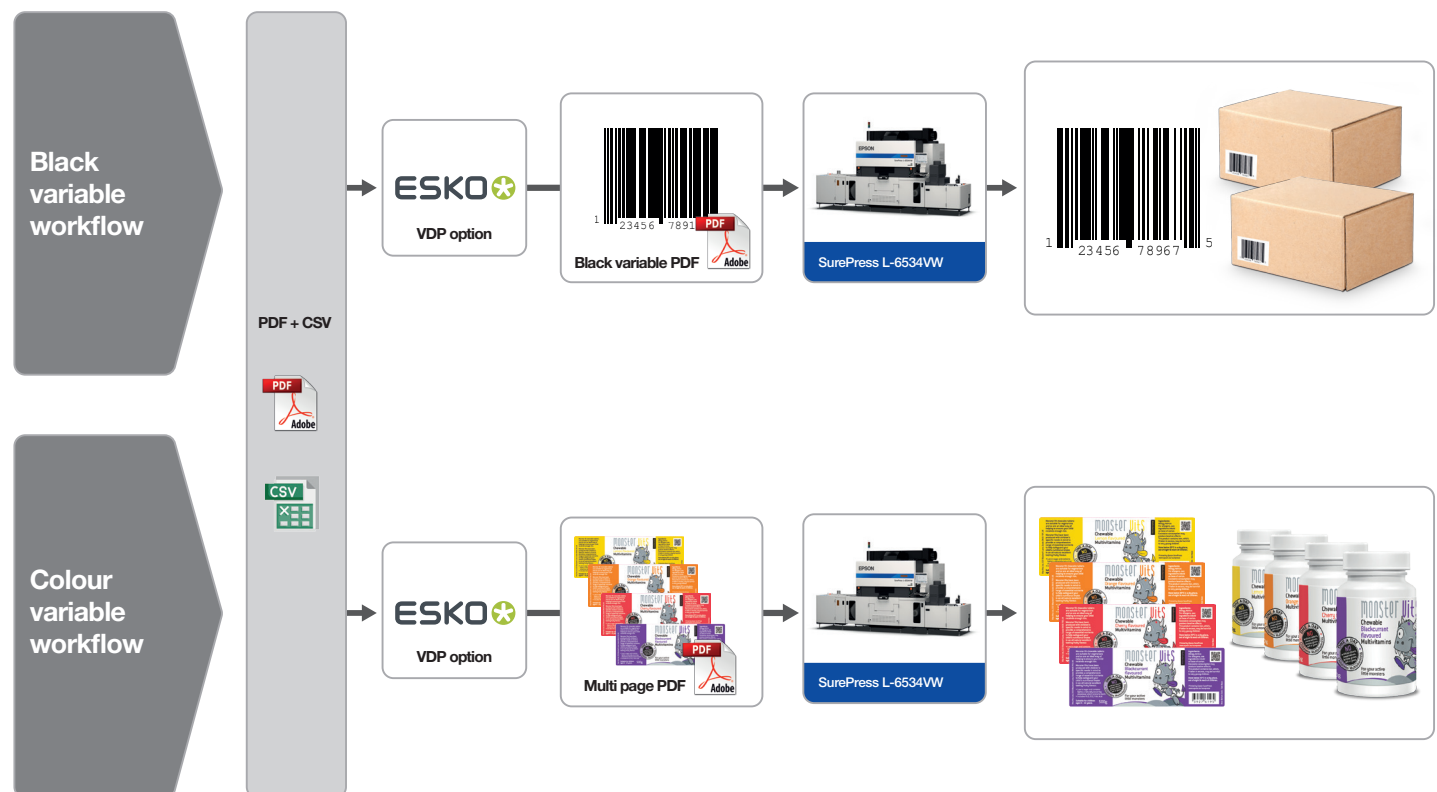

# SurePress Customer Support Service

Epson label presses are dependable, efficient, and easy to operate. If help is required our worldwide Epson trained service technicians are ready to offer expert support to SurePress users.

The operational status of the SurePress is monitored using a remote server. Relying on an extensive network of sensors that feed into a diagnostic system, the L-6534VW monitoring system allows for real-time predictive analysis and remote response - all done in advance of an on-site visit by a technician.

Our service technicians undergo intensive training to offer fast and efficient support to our customers, remotely and on-site.

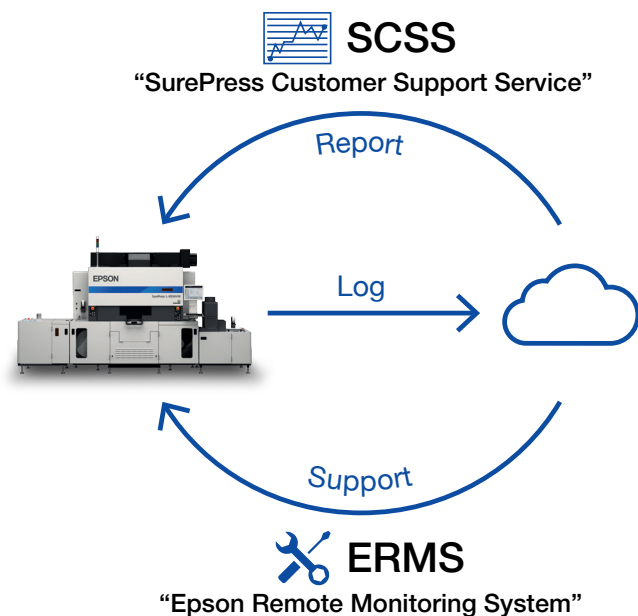

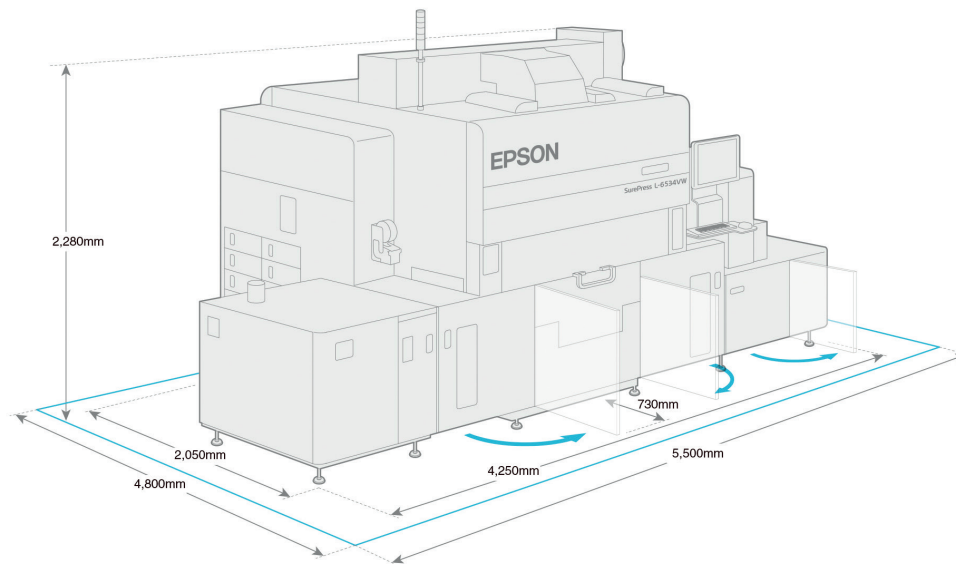

Model		SurePress L-6534VW (CMYK+ Orange + White ink)
Print	Print Technology	PrecisionCore linehead inkjet technology
	Maximum Print Resolution	600 x 1200 dpi
	Gradation Process	Variable-Sized Droplet Technology
	Maximum Image Size	330mm x 1000mm
Ink	Ink Type	UV Curable Inks
	Ink Cartridges	Black, Cyan, Magenta, Yellow, Orange, White, Storage liquid
Print Speed	Productivity Mode	50m/min
	Standard Mode	30m/min
	High Density Mode	15m/min
	Reverse White Mode	7.6m/min
Substrate	Substrate Width	80mm to 340mm
	Substrate Type	Coated paper, Uncoated paper and Foil. PP, PE, PET and Yupo™
	Substrate Thickness	80 to 320 microns
	Unwinder Capacity	600mm diameter / 100kg weight / 1000m length
Dimensions (W x D x H)		4250mm x 2050mm x 2280mm, (included Corona Treater and Additional UV Lamp Curing Unit)
Weight		Approx. 2,632kg (included Corona Treater and Additional UV Lamp Curing Unit)
Environment	Temperature	20 - 28°C
	Humidity	RH 35 - 55%, Non-condensing required
	Space For Operation	5.5m x 4.8m x 2.8m (W x D x H)
Electric Supply	Main Unit	AC 200V +/- 10% (3 phases 3 lines + protective earthing) 30A
	Corona Treater	AC 200 - 240V +/- 10% (Single phase + protective earthing) 15A
	Additional UV Lamp	AC 200 - 240V +/- 10% (Single phase + protective earthing) 40A
Exhaust	Main Unit	35 - 45m³/min Ø250mm
	Corona Treater	5m³/min or more Ø100mm
	Additional UV Lamp	10 - 15m³/min Ø200mm, 150mm
Compressed Air		0.5 - 1.0Mpa
Network		10BASE-T/100BASE-T/1000BASE-T

\* Warranty offers are not available for all countries. Please contact your local Epson representative.

For further information please contact your local Epson office or visit [www.epson.eu/contact-us](http://www.epson.eu/contact-us)

Algeria +213 770 938 617 Austria 01 253 49 78 333 Belgium +32 (0)2 792 04 47 Czech +420 246 037 281 Denmark 44 50 85 85 East Africa (+254) 734 354 075  
 Finland 0201 552 091 France 09 74 75 04 04 (Cost of local call, operator charges may apply) Germany +49 (0) 2159/92 79 500 Greece (0030) 211 198 62 12  
 Hungary 06800 147 83 Ireland 01 436 7742 Israel (+972)-3-5751833 Italy 02-660321 10 (0,12 €/min) Luxembourg +352 27860692 Middle East +9714 2677638  
 Morocco +212 520 134 040 Netherlands +31 (0)20 708 5099 Norway +47 67 11 37 00 Poland +48 22 295 37 25 (0,16 zł/min) Portugal 707 222 111  
 Romania 0040 214025024 Russia (095) 777-03-55 Slovakia +421 232 786 682 Southern Africa +27 (0) 10 109 5320 Spain 93 582 15 00 Sweden +46 8 5051 3701  
 (Mobilsamtal – 0,99 kr/min, Lokala samtal – 0,30 kr/min, Utlandssamtal – 0,89 kr/min) Switzerland 022 592 7923 Tunisia +216 9811 5564 Turkey (0212) 3360303  
 United Kingdom 0871 42 37766 (+10p per minute plus network extras) West Africa (+234)8020727843

Trademarks and registered trademarks are the property of Seiko Epson Corporation or their respective owners.  
 Product information is subject to change without prior notice.

**EPSON®**